

Contract Administration: To Be Lifecycle

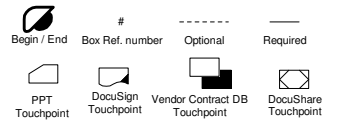

Initiator(Sourcing Managers) / Initiator Group:

Contracts Administration

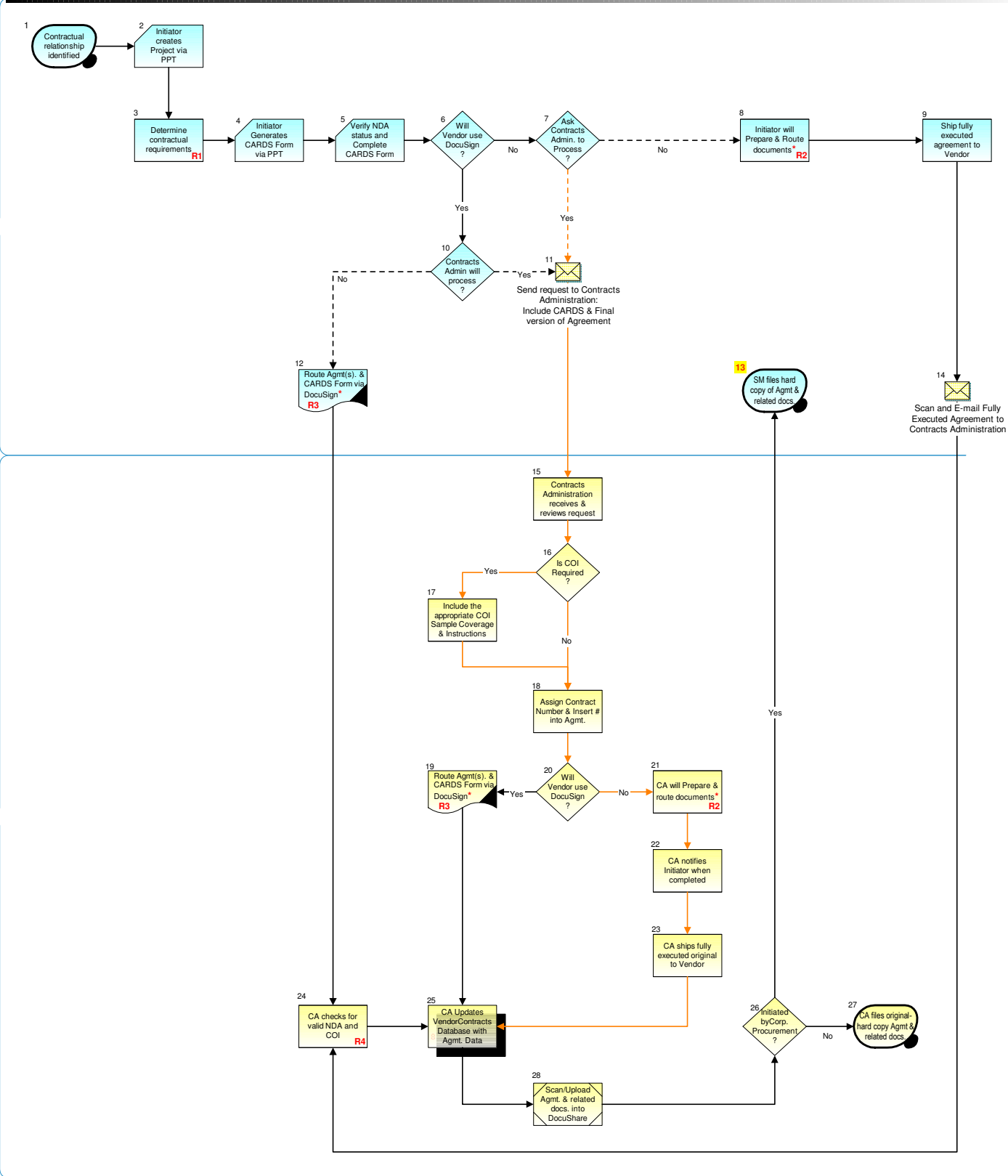

SM - Sourcing Manager
CA - Contracts Administrator

PPT - Procurement Project Tool
CARDS - Contract Approval Routing & Deal Summary:

R1 Process Detail Reference: Contract Review and Modification Procedure
R2 Process Detail Reference: Administered Approval Routing
R3 Process Detail Reference: DocuSign Approval Routing
R4 Process Detail Reference: COI & NDA Procedure

*When applicable, an NDA is included with Agreement execution request.

Contract Renewal Notification To Be Process

Contracts Administration

Initiator(Sourcing Managers) / Initiator Group:

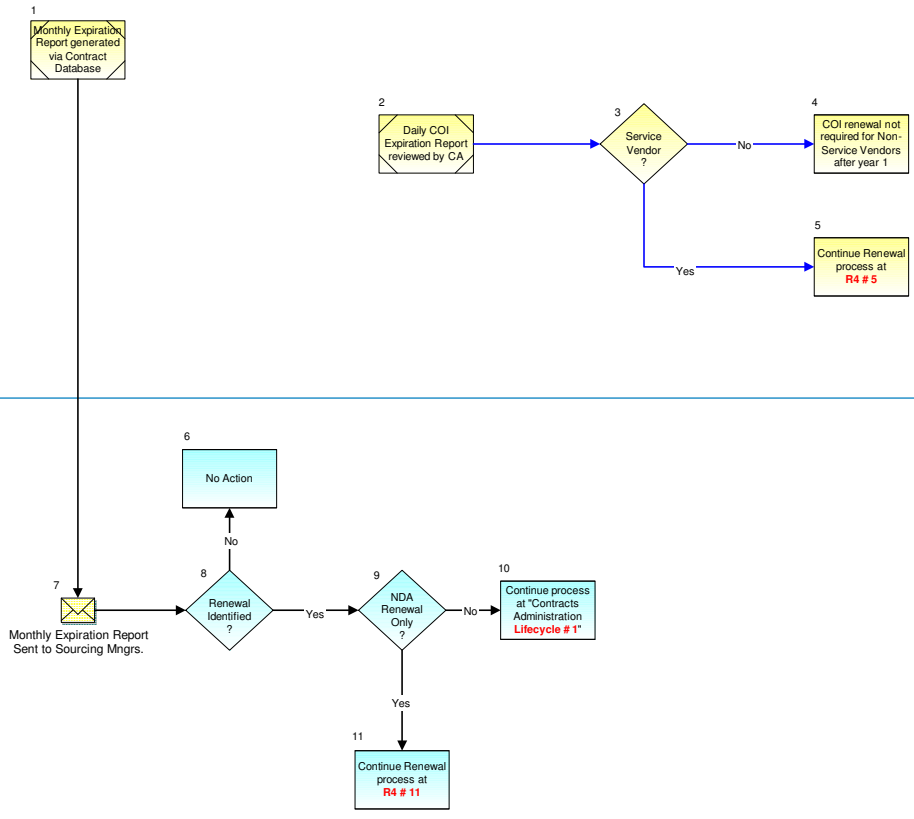

SM - Sourcing Manager
CA - Contracts Administrator

PPT - Procurement Project Tool
CARDS - Contract Approval Routing & Deal Summary:

R1 Process Detail Reference: Contract Review and Modification Procedure
R2 Process Detail Reference: Administered Approval Routing
R3 Process Detail Reference: DocuSign Approval Routing
R4 Process Detail Reference: COI & NDA Procedure

Contract Administration: Administered Approval Routing To Be Process R2

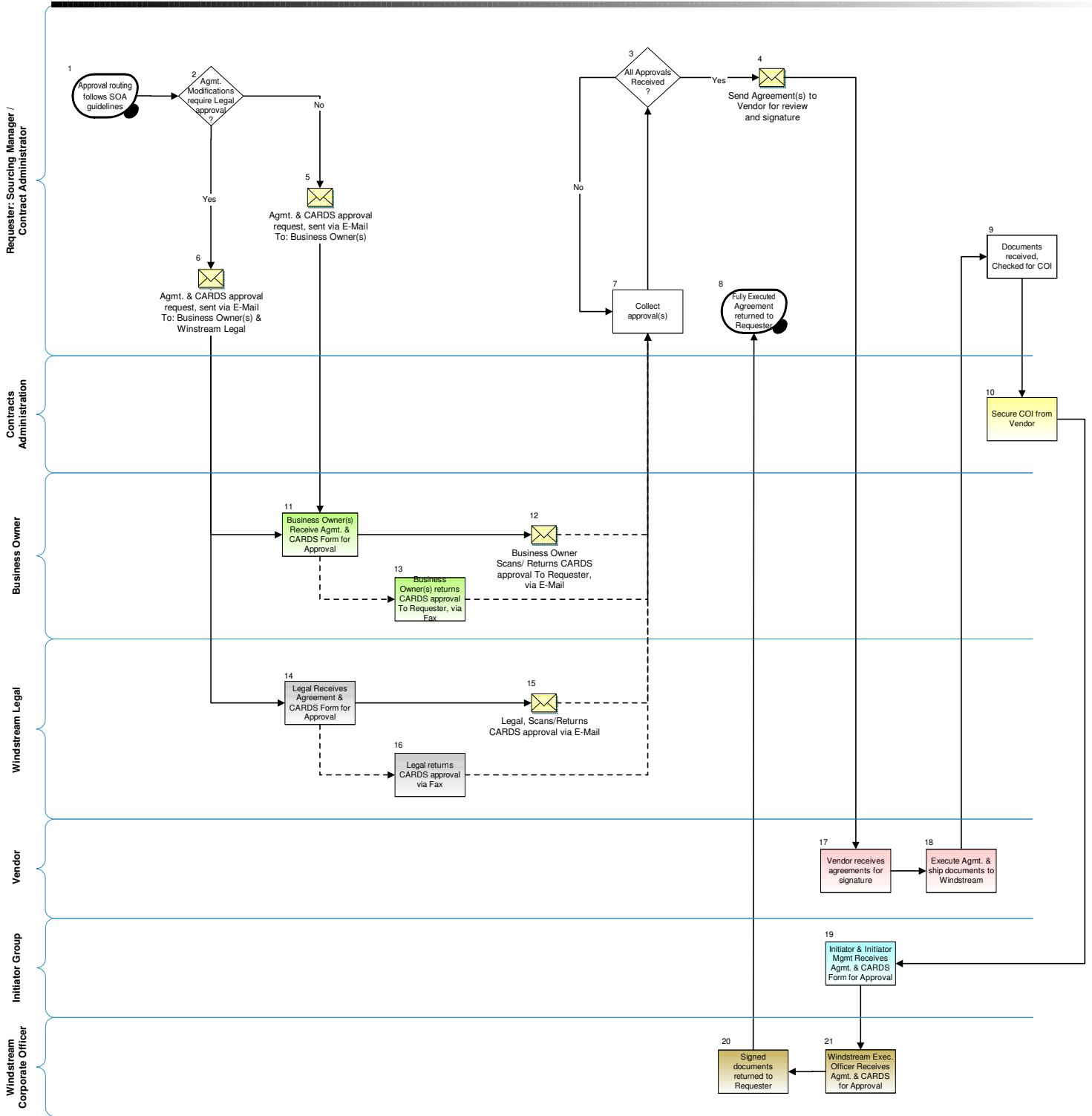
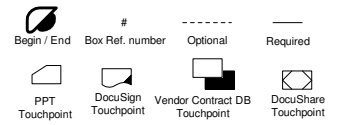

SOA - Schedule of Authorization

PPT - Procurement Project Tool
CARDS - Contract Approval Routing & Deal Summary:

R1 Process Detail Reference: Contract Review and Modification Procedure
R2 Process Detail Reference: Administered Approval Routing
R3 Process Detail Reference: DocuSign Approval Routing
R4 Process Detail Reference: COI & NDA Procedure

Contract Administration: DocuSign Approval Routing To Be Process R3

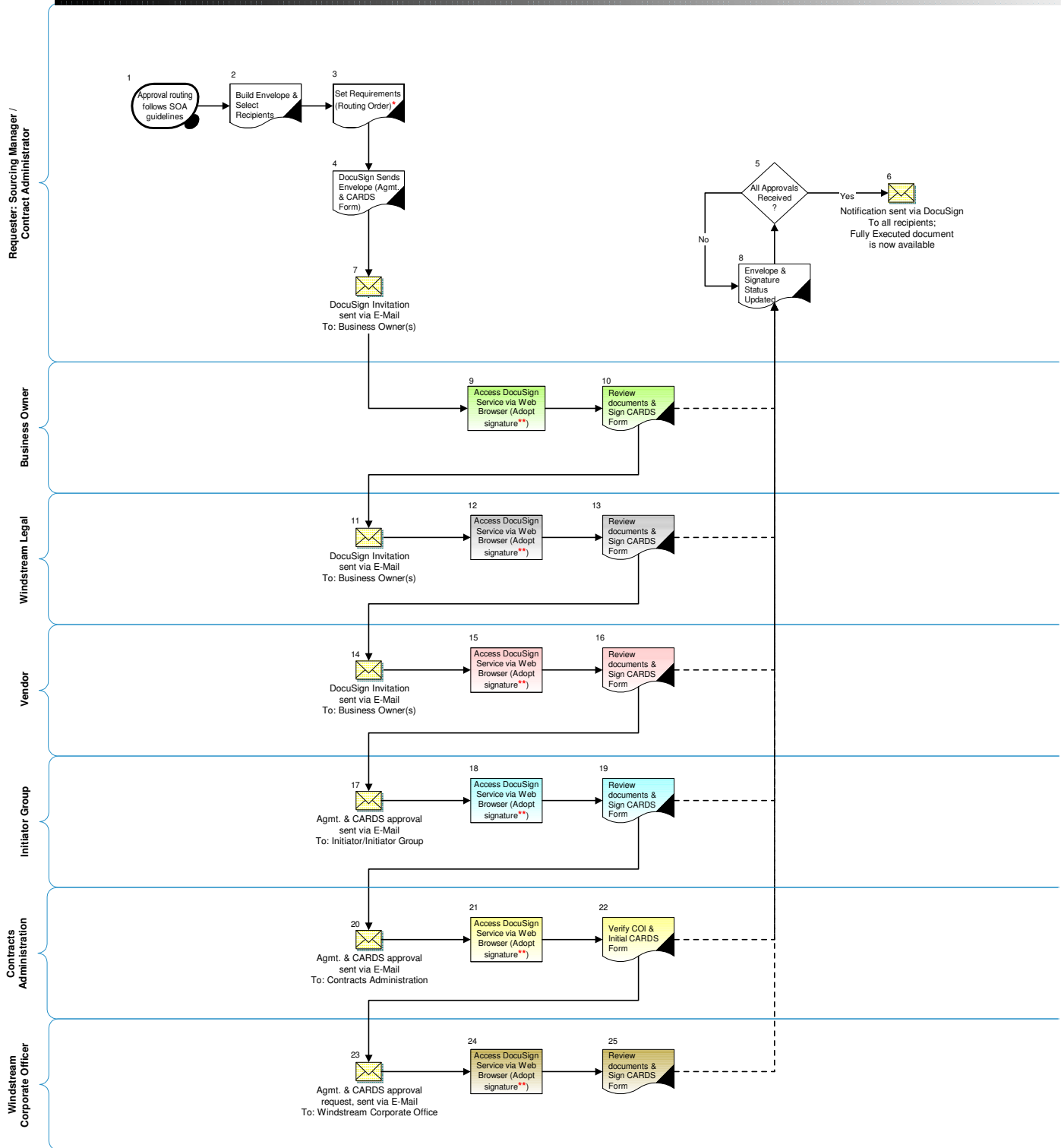
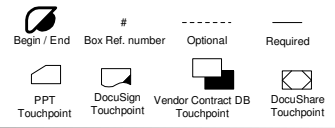

*The routing order determines the required approval path for the DocuSign Envelope
 **An electronic signature is required to use the DocuSign Service.

PPT - Procurement Project Tool
 CARDS - Contract Approval Routing & Deal Summary:

R1 Process Detail Reference: Contract Review and Modification Procedure
 R2 Process Detail Reference: Administered Approval Routing
 R3 Process Detail Reference: DocuSign Approval Routing
 R4 Process Detail Reference: COI & NDA Procedure

Certificate of Insurance(COI) & Non-Disclosure Agreement(NDA) To Be Process R4

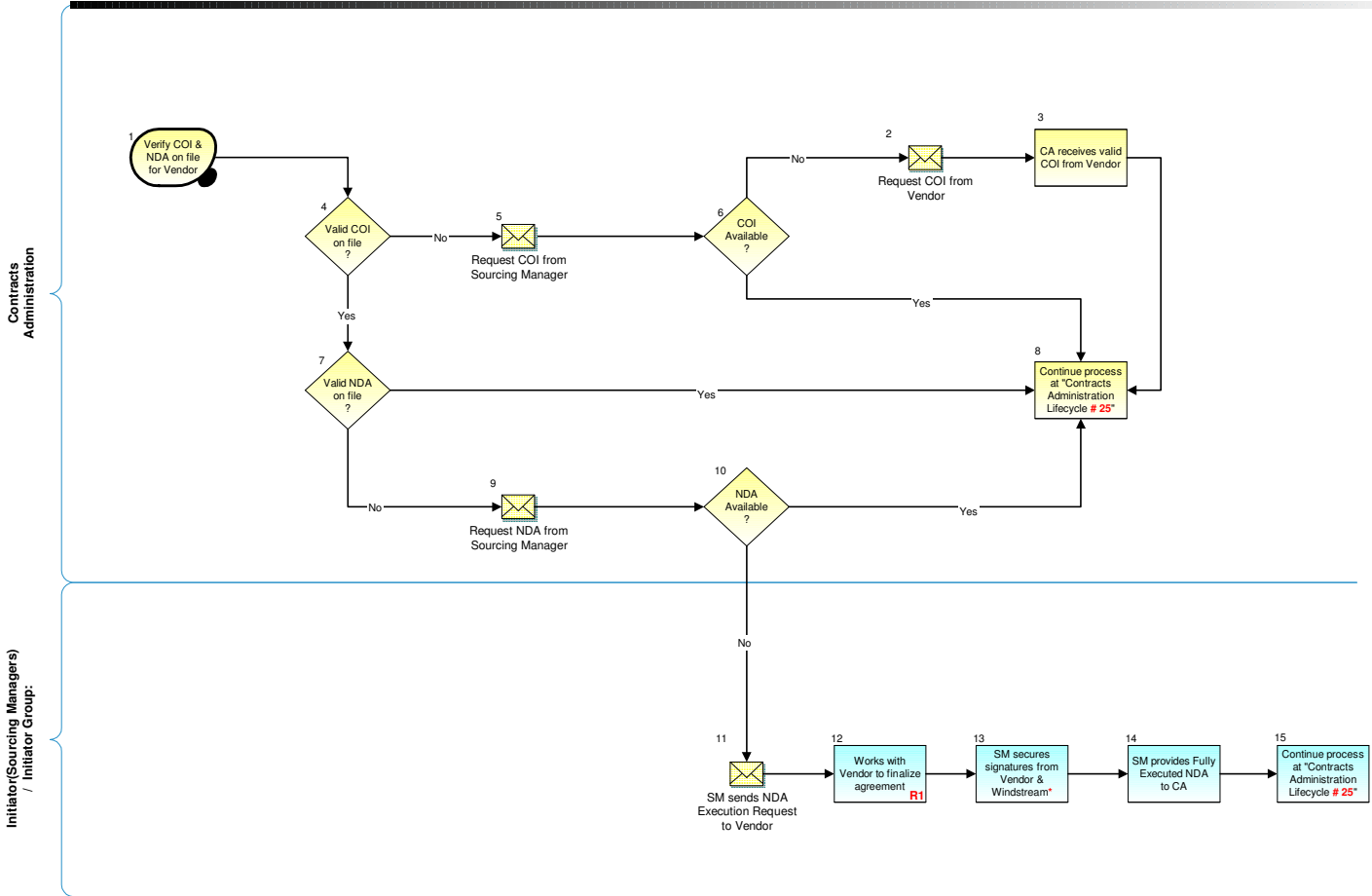
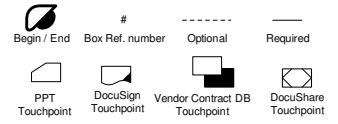

*Via DocuSign or Administered manual process

PPT - Procurement Project Tool
CARDS - Contract Approval Routing & Deal Summary;

R1 Process Detail Reference: Contract Review and Modification Procedure
R2 Process Detail Reference: Administered Approval Routing
R3 Process Detail Reference: DocuSign Approval Routing
R4 Process Detail Reference: COI & NDA Procedure